



TOOLS REQUIRED

- 5/16" Box/ End Wrench
- 1/2" Box/End Wrench
- 1/4" Ratchet and 6" Extension
- 1/2" Socket 1/4" Drive
- 3/8" Ratchet with 9/16" Socket
- Flat Blade Screw Driver
- 3/16" Allen Wrench
- 5/16" Nut Drive
- Snap Ring Pliers
- Hi-Temp Silicone Sealer

ITEMS SUPPLIED

Description	Part #	Qty
2 into 1 Header and Muffler		1
Front Heat Shield		1
Rear Heat Shield		1
Collector Heat Shield		1
Softail 2-1 Frame Mounting Bracket	25-00220	1
2 5/8" Barrel Clamp	16-00290	1
James Exhaust Gasket	20-00003	1pr
5/16-18" NyLock Nut	35-00005	2
5/16-18 x 3/4" Hex Bolt	35-00003	2
5/16 Flat Washer	35-00007	2
O2 Bung Plug 18mm	35-00083BA	2
2 1/4" Stainless Steel Hose Clamp	16-00285	6
3" Stainless Steel Hose Clamp	16-00295	1
1/2" Spacer	29-00028B	2
3/8-16 x 1.25" Hex Head Bolt	35-00032	2
3/8" Flat Washers	35-00037	2
Instructions & Warranty		1

PLEASE NOTE

Our warranty applies only when the system is installed correctly and used for its intended purpose. Warranty does not apply when damage is the result of normal wear and tear, improper use, neglect or incorrect engine configuration. See warranty notice in box for more information.

Installation Instructions

HARLEY DAVIDSON SOFTAIL 1986-2013 2 into 1 EXHAUST SYSTEM

Rev 7-6-2015

Thank you for buying a RINEHART exhaust system. We are committed to providing you a quality product that with the proper installation and care will last you for many years to come.

Please be sure to read the instructions fully and inspect all components of your new system before installation. If you do not have an understanding of how to remove your stock system, or how to install the RINEHART exhaust system you should seek the advice and/or skill of a professional mechanic. Please keep all OEM parts as some may be used for the installation of the RINEHART exhaust system. If you are installing the system and are not the owner, please return these instructions to the owner as they contain important information that may be required at a later date.

If you have questions pertaining to the installation, please contact our technical service department: 1.877.263.5216 or www.rinehartracing.com

Exhaust systems manufactured by Rinehart racing are non-catalyst. A stock catalyst exhaust system cannot be replaced with a non catalyst exhaust system. Please verify the application with your dealer before purchase.

INSTALLATION INSTRUCTIONS

Disconnect negative battery terminal before starting any work.

1. If applicable, unplug the rear OEM O₂ sensor located under the oil tank on the right side of the bike. Feed wire through frame. Note the wire routing, as it will be reinstalled.
2. If applicable, unplug front OEM O₂ sensor. Remove the nylon tie holding the wire to the frame.
3. On all models with floor boards, loosen the floor board mounting bolt to provide better access to the exhaust system.
4. Remove the OEM exhaust system along with the stock rear mounting bracket.
5. Carefully remove OEM exhaust flanges and retaining rings. Do not damage or distort the retaining rings. If possible use snap ring pliers. Replace damaged retaining rings.
6. Slide the exhaust flange and retainer rings onto the RINEHART exhaust headers. The machined recess should face the retainer ring.
7. Remove the OEM exhaust gaskets from the cylinder heads. It may be necessary to pry the exhaust gaskets from the head using a scribe or a small screwdriver. Do not damage the cylinder head!
8. Replace OEM exhaust gaskets with the supplied James Gaskets, make sure to seat the new gaskets into the cylinder head. Failure to use provided James Gaskets WILL alter the fitment of the system.
9. Install new mounting bracket (supplied) finger tightening (2) 3/8-16 x 1.25" hex bolts (supplied), (2) 3/8" flat washers (supplied), and (2) 1/2" spacers (supplied) between the bracket and frame. Torque to 25-30 ft.lbs.
10. If applicable, remove OEM O₂ sensors from the OEM exhaust and install in your new system. Hint: apply a small amount of anti-seize to the threads on the sensor before installing. Torque to manufacturer specification. If not applicable, install 18mm Bung Plugs into header pipe with anti-seize and same torque specification.
11. Install the Rinehart 2-1 header. Place in the front cylinder first and then the rear. It may be necessary to pull back slightly on the header to get it in the rear cylinder head.
12. Tighten the cylinder head exhaust flange nuts. Torque to 10-12ft lbs.

TUNING

Adjustment of fuel injection is REQUIRED to optimize performance and minimize chrome discoloration. We recommend that adjustment of fuel injection be performed by QUALIFIED technicians on a dynamometer utilizing an Exhaust Gas Analyzer.

13. Install the heat shield clamps into the heat shields.
14. Install the heat shields starting with the rear pipe first, then the front pipe, and then the collector heat shield.
Leave the collector heat shield loose, failure to do so may result in scratching the muffler! An extra set of hands is helpful to guide the muffler body onto the head pipe. **Tech Tip: Use black electrical tape on the collector edge to prevent scratching the muffler.**
15. Slide the 2 5/8" barrel clamp over the inlet of the muffler. Note: Apply a bead of Permatex Ultra Copper High Temp Silicone Sealer to muffler inlet. Now slide the muffler body onto the header pipe, with the end cap screws toward the rear tire of the motorcycle. Install the 5/16-18" x 5/8" hex bolts (supplied) into the muffler mounting bracket and install through the frame mounting bracket. Install 5/16" x 18" locking nuts (supplied) and tighten. Torque 8-10ft lbs.
16. Torque the 2 5/8" barrel clamp to 8-10ft lbs.
17. Tighten the collector heat shield clamp.
18. Route O₂ sensor wires to their original connection points and plug into their respective mating connectors. Secure front wire to the frame with a nylon tie strap.
19. Tighten the right front floor board. Torque to 15 ft.lbs.

Important! Wipe down complete system with glass cleaner **before** starting bike to remove any finger prints or dirt.
Note: Finger prints that are not removed before running will become permanently etched in the pipes.

Enjoy your new Rinehart System.

Check all fasteners after first ride and again at all service intervals.

CLEANING

Never use harsh chemicals or any type of abrasive material to clean the chrome or ceramic coating on this exhaust system. We recommend using a soft non-abrasive cloth with a mild detergent such as liquid dish soap.

CONTACT US

Rinehart Racing
1-877-264-8282
www.rineharttracing.com

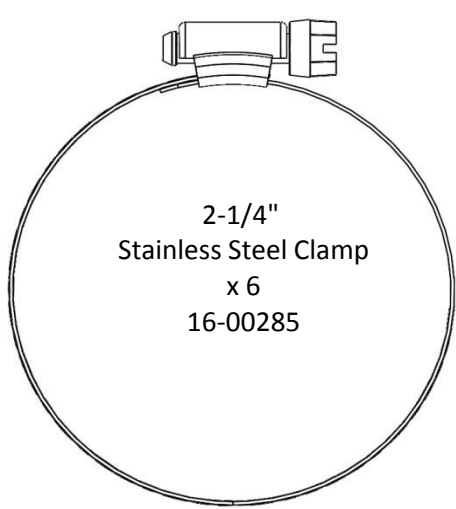

2-1/4"
Stainless Steel Clamp
x 6
16-00285

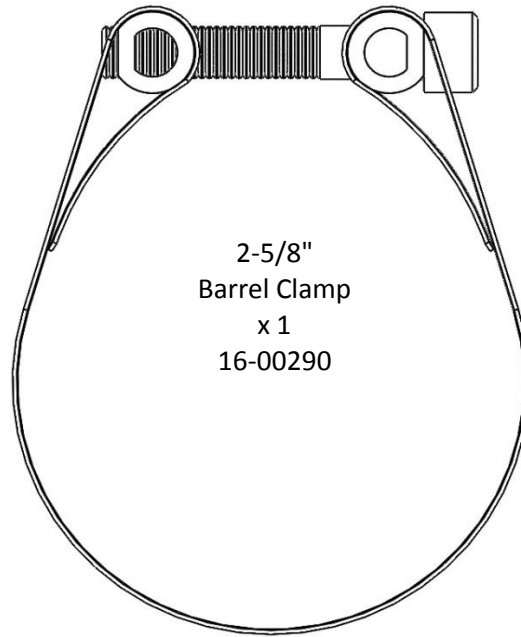

2-5/8"
Barrel Clamp
x 1
16-00290



3"
Stainless Steel Clamp
x 1
16-00295

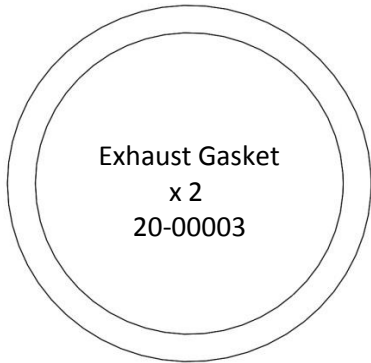

Exhaust Gasket
x 2
20-00003



1/2"
Front Floorboard Spacer
x 2
29-00028B

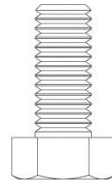

5/16" x 3/4"
Hex Bolt
x 2
35-00003



5/16"
Locking Nut
x 2
35-00005

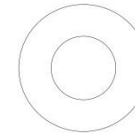

5/16"
Flat Washer
x 2
35-00007

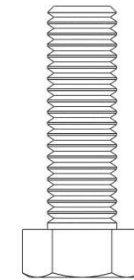

3/8" x 1-1/4"
Hex Bolt
x 2
35-00032

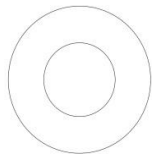

3/8"
Flat Washer
x 2
35-00037

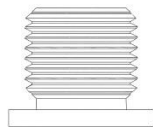

18 mm
O2 Bung Plug
x 2
35-00083BA

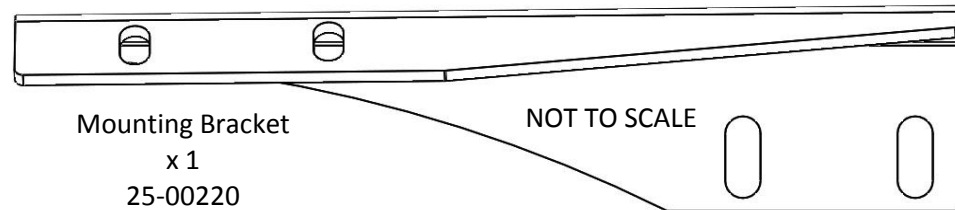

Mounting Bracket
x 1
25-00220

NOT TO SCALE